

SECTION NO.
931-024

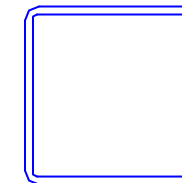
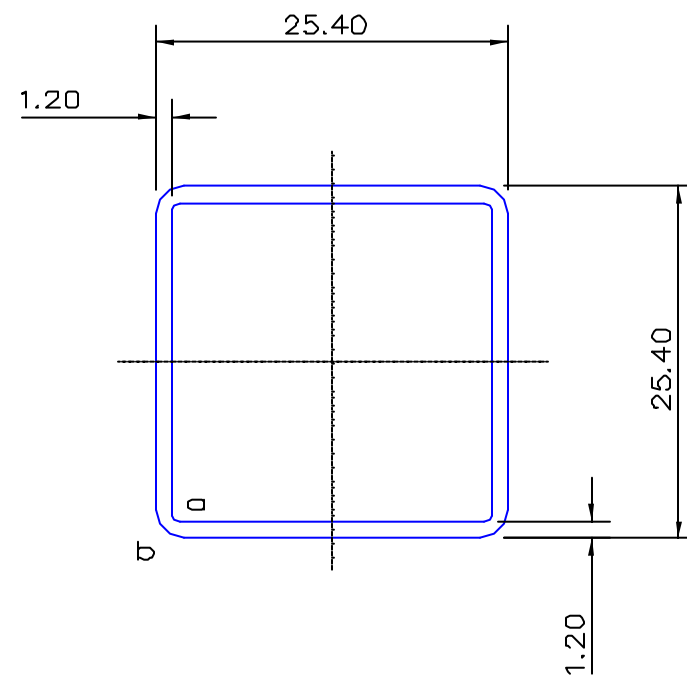

TOTAL EXPOSED SURFACE
ACTUAL SIZE

SECTION DATA:
 $I_{xx} = 10\,878\text{ mm}^4$
 $I_{yy} = 10\,878\text{ mm}^4$
 $\text{Theta} = 1.0$
 $\text{RadG}_x = 10\text{ mm}$
 $\text{RadG}_y = 10\text{ mm}$
 $X_{\text{right}} = 12.70\text{ mm}$
 $X_{\text{left}} = 12.70\text{ mm}$
 $Y_{\text{top}} = 12.70\text{ mm}$
 $Y_{\text{bot}} = 12.70\text{ mm}$
 $Z_{x\text{top}} = 857\text{ mm}$
 $Z_{x\text{bot}} = 857\text{ mm}$
 $Z_{y\text{right}} = 857\text{ mm}$
 $Z_{y\text{left}} = 857\text{ mm}$

a = 0.50 radius
b = 2.00 radius

0.40 RADIUS ON ALL OUTSIDE CORNERS
UNLESS OTHERWISE SPECIFIED

EXTRUDED FINISH : ARCHITECTURAL

			A		AREA	112.9	SQ MM	 G. James Extrusion Co. A.C.N 010 828 234 1082 KINGSFORD SMITH DRIVE, EAGLE FARM, QUEENSLAND, 4009 PO BOX 1376, EAGLE FARM BC, 4009 PHONE : (07) 3877 2833 FAX : (07) 3877 2890	CUSTOMER		G. JAMES EXTRUSION Co.	
					WEIGHT	0.306	KG M		CUSTOMER PART NAME		25.40 x 1.2 SQUARE TUBE R/C	
					PERIMETER	189.3	MM		SCALE		2:1	
					ANOD PERIM	98.2	MM		TOLERANCES IN ACCORDANCE WITH AS 1866-1986		APPLY UNLESS OTHERWISE SPECIFIED	
					PAIN PERIM	100.0 (0.0)	MM		DRAWN		RB	
					CIRCLE DIA	34	MM		CHECK		DATE	
					FACTOR	619			DATE		11/07/89	
					ALLOY	6063			DWG. NO.		931-024	
					TEMPER	T6						
1	01/08/89	BPW	TYPICAL WALL THK WAS 1.50									
NO	DATE	DR	REVISION									