

SECTION NO.
931-145

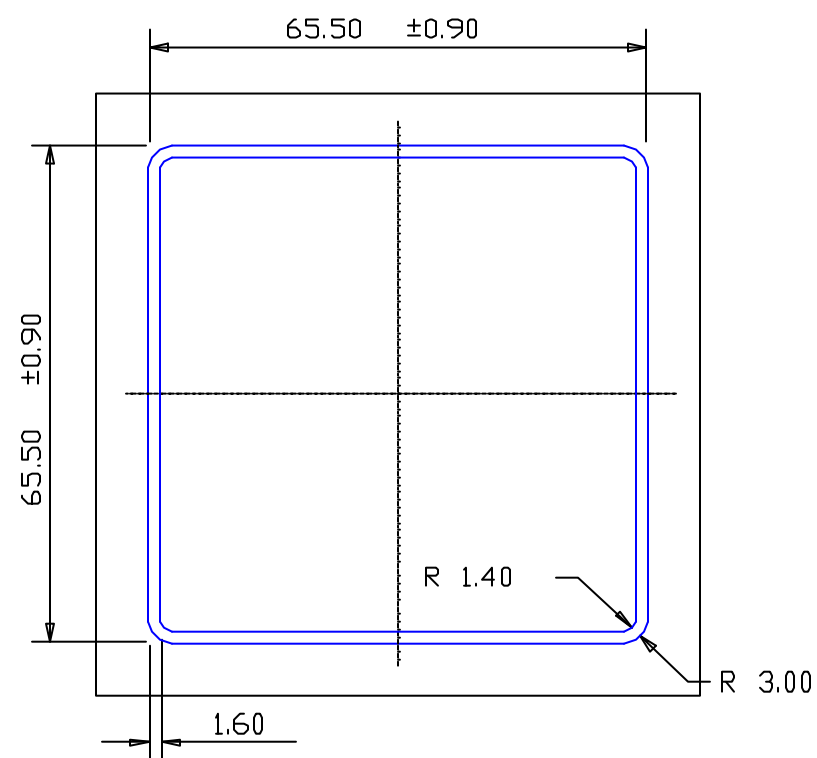

TOTAL SURFACE EXPOSED

SECTION DATA:
 $I_{xx} = 272\,133\text{ mm}^4$
 $I_{yy} = 272\,133\text{ mm}^4$
 $\text{Theta} = 1.0^\circ$
 $\text{RadG}_x = 26\text{ mm}$
 $\text{RadG}_y = 26\text{ mm}$
 $\text{XC}_{\text{Right}} = 32.8\text{ mm}$
 $\text{XC}_{\text{Left}} = 32.8\text{ mm}$
 $\text{YC}_{\text{top}} = 32.8\text{ mm}$
 $\text{YC}_{\text{bot}} = 32.8\text{ mm}$
 $Z_{xx\text{top}} = 8\,309\text{ mm}^3$
 $Z_{xx\text{bot}} = 8\,309\text{ mm}^3$
 $Z_{yy\text{right}} = 8\,309\text{ mm}^3$
 $Z_{yy\text{left}} = 8\,309\text{ mm}^3$

1.60±0.25 TYP WALL THICKNESS
UNLESS OTHERWISE SPECIFIED

0.40 RADIUS ON ALL OUTSIDE CORNERS
UNLESS OTHERWISE SPECIFIED

EXTRUDED FINISH + ARCHITECTURAL

			A	AREA	402.9	SQ MM	 G. James Extrusion Co. A.C.N 010 828 234 1082 KINGSFORD SMITH DRIVE, EAGLE FARM, QUEENSLAND, 4009 PO BOX 1376, EAGLE FARM BC, 4009 PHONE : (07) 3877 2833 FAX : (07) 3877 2890	CUSTOMER		G. JAMES EXTRUSION Co.	
				WEIGHT	1.092	KG M		CUSTOMER PART NAME		NO.	
				PERIMETER	503.6	MM		65.5 x 65.5 x 1.6 R/CNR SQR TUBE			
				ANOD PERIM	256.8	MM		SCALE		TOLERANCES IN ACCORDANCE WITH AS 1866-1986 APPLY UNLESS OTHERWISE SPECIFIED	
				PAINT PERIM	256.8 (0.0)	MM		1:1			
				C CIRCLE DIA	90	MM		DRAWN		CHECK	
				FACTOR	461			PAD		DATE	
2	06/06/02	PAD	SECTION NO. WAS RAB-004	ALLOY	6063				26/05/02		
1	29/05/02	PAD	1.60 TYPICAL WALL THK WAS 1.50	TEMPER	T5				DWG. NO.		
NO	DATE	DR	REVISION							931-145	