

SECTION NO.
931-148

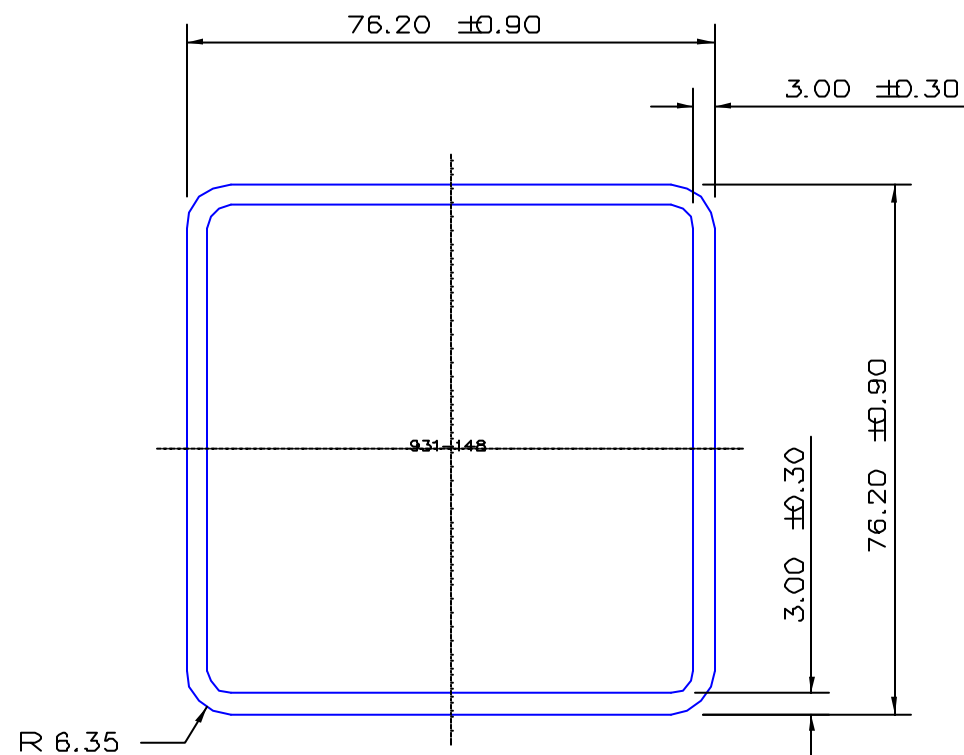

TOTAL SURFACE EXPOSED

SECTION DATA:
 $I_{xx} = 750\,513 \text{ mm}^4$
 $I_{yy} = 750\,513 \text{ mm}^4$
 $\text{Theta} = 1.0^\circ$
 $\text{RadG}_x = 30. \text{ mm}$
 $\text{RadG}_y = 30. \text{ mm}$
 $X_{\text{Right}} = 38.1 \text{ mm}$
 $X_{\text{Left}} = 38.1 \text{ mm}$
 $Y_{\text{Top}} = 38.1 \text{ mm}$
 $Y_{\text{Bot}} = 38.1 \text{ mm}$
 $Z_{x\text{top}} = 19\,699 \text{ mm}$
 $Z_{x\text{bot}} = 19\,699 \text{ mm}$
 $Z_{y\text{right}} = 19\,699 \text{ mm}$
 $Z_{y\text{left}} = 19\,699 \text{ mm}$

0.40 RADIUS ON ALL OUTSIDE CORNERS
UNLESS OTHERWISE SPECIFIED

EXTRUDED FINISH : ARCHITECTURAL

				<p>AREA 853.4 SQ MM</p> <p>WEIGHT 2.313 KG M</p> <p>PERIMETER 568.9 MM</p> <p>ANOD PERIM 293.9 MM</p> <p>PAINT PERIM 293.9 (0.0) MM</p> <p>CIRCLE DIA 103. MM</p> <p>FACTOR 246.</p> <p>ALLOY 6063</p> <p>TEMPER T6</p>		 <p>G. James Extrusion Co.</p> <p>A.C.N 010 828 234</p> <p>1082 KINGSFORD SMITH DRIVE, EAGLE FARM, QUEENSLAND, 4009</p> <p>PO BOX 1376, EAGLE FARM BC, 4009</p> <p>PHONE : (07) 3877 2833 FAX : (07) 3877 2890</p>		CUSTOMER	
A				G. JAMES EXTRUSION Co.				CUSTOMER PART NAME NO.	
						76.2 x 3.0 SQR BOX (RAD CNRS)			
						SCALE			
						1:1			
						TOLERANCES IN ACCORDANCE WITH AS 1866-1986 APPLY UNLESS OTHERWISE SPECIFIED			
						DRAWN			
						SPG			
						CHECK			
						DATE			
						22/09/99			
						DWG. NO.			
						931-148			
NO	DATE	DR	REVISION						