

SECTION NO.
931-158

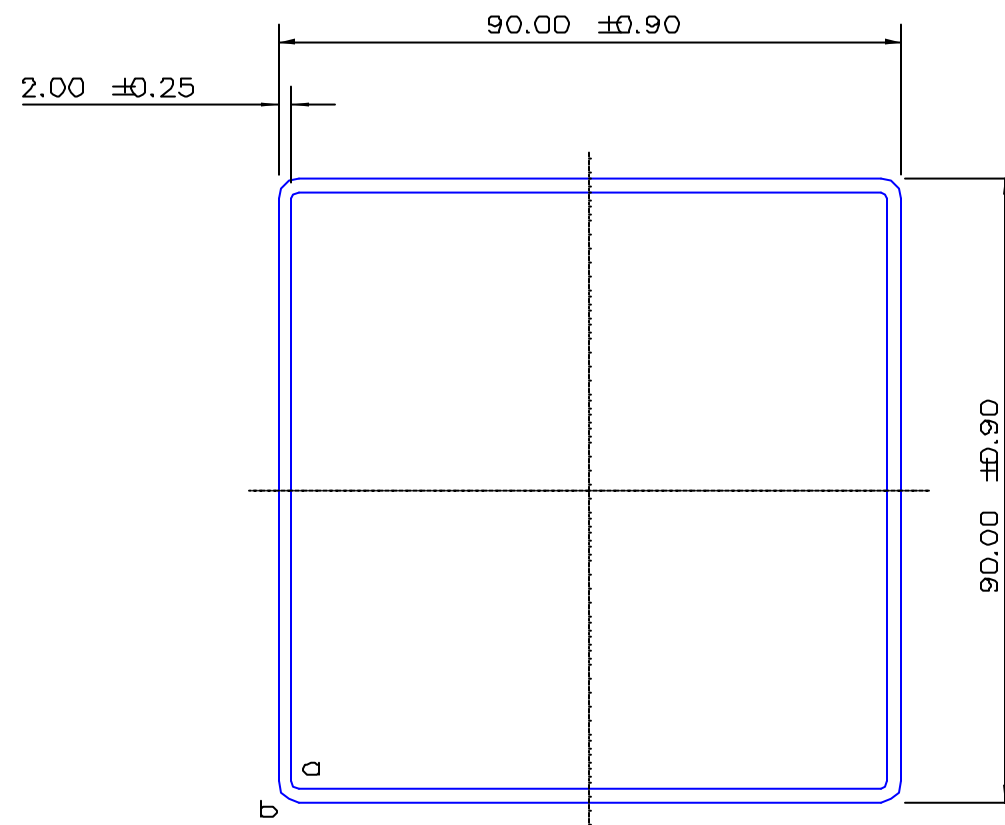

TOTAL SURFACE EXPOSED

SECTION DATA:
 $I_{xx} = 895\,485 \text{ mm}^4$
 $I_{yy} = 895\,485 \text{ mm}^4$
 $\text{Theta} = 1.0$
 $\text{RadG}_x = 36. \text{ mm}$
 $\text{RadG}_y = 36. \text{ mm}$
 $X_{\text{Right}} = 45.00 \text{ mm}$
 $X_{\text{Left}} = 45.00 \text{ mm}$
 $Y_{\text{Top}} = 45.00 \text{ mm}$
 $Y_{\text{Bot}} = 45.00 \text{ mm}$
 $Z_{x\text{top}} = 19\,900 \text{ mm}$
 $Z_{x\text{bot}} = 19\,900 \text{ mm}$
 $Z_{y\text{right}} = 19\,900 \text{ mm}$
 $Z_{y\text{left}} = 19\,900 \text{ mm}$

a = 1.00 radius
b = 3.00 radius

2.00 ±0.25 TYP WALL THICKNESS
UNLESS OTHERWISE SPECIFIED

0.40 RADIUS ON ALL OUTSIDE CORNERS
UNLESS OTHERWISE SPECIFIED

EXTRUDED FINISH : ARCHITECTURAL

| | | | | | | | | | |
|----|------|----|----------|---|--|---|--|------------------------|--|
| | | | | <p>AREA 697.1 SQ MM</p> <p>WEIGHT 1.889 KG M</p> <p>PERIMETER 697.1 MM</p> <p>ANOD PERIM 354.8 MM</p> <p>PAINT PERIM 354.8 (0.0) MM</p> <p>CIRCLE DIA 125. MM</p> <p>FACTOR 369.</p> <p>ALLOY 6063</p> <p>TEMPER T5</p> | |  <p>G. James Extrusion Co.</p> <p>A.C.N 010 828 234</p> <p>1082 KINGSFORD SMITH DRIVE, EAGLE FARM, QUEENSLAND, 4009</p> <p>PO BOX 1376, EAGLE FARM BC, 4009</p> <p>PHONE : (07) 3877 2833 FAX : (07) 3877 2890</p> | | CUSTOMER | |
| | | | | G. JAMES EXTRUSION Co. | | | | CUSTOMER PART NAME NO. | |
| | | | | | | 90 x 90 x 2 SQUARE BOX R/CNRS | | | |
| | | | | | | SCALE | | | |
| | | | | | | 1:1 | | | |
| | | | | | | TOLERANCES IN ACCORDANCE WITH AS 1866-1986 APPLY UNLESS OTHERWISE SPECIFIED | | | |
| | | | | | | DRAWN CHECK DATE DWG. NO. | | | |
| | | | | | | SPG 28/11/01 931-158 | | | |
| NO | DATE | DR | REVISION | | | | | | |