



Rules of Hockey
Including Explanations
Effective from 1 January 2004

Copyright © FIH 2003

The International Hockey Federation
Avenue des Arts 1 Bte 5
B-1210 Brussels
Belgium

Telephone: ++32 (2) 219 4537
Fax: ++32 (2) 219 2761
E-mail: FIH@FIHockey.org
Internet: www.FIHockey.org

Responsibility and Liability

Participants in hockey must be aware of the Rules of Hockey and of other information in this publication. They are expected to perform according to the Rules.

Emphasis is placed on safety. Everyone involved in the game must act with consideration for the safety of others. Relevant national legislation must be observed. Players must ensure that their equipment does not constitute a danger to themselves or to others by virtue of its quality, materials or design.

The International Hockey Federation (FIH) does not accept responsibility for any defects or non-compliance of facilities and is not liable for any consequences resulting from their use. Any verification of facilities or equipment conducted before a match is limited to ensuring an overall appearance of compliance and sporting requirements.

Umpires exercise an important role controlling the game and ensuring fair play.

Implementation and Authority

The Rules of Hockey apply to all hockey players and officials. National Associations have discretion to decide the date of implementation at national level. The date of implementation for international competition is 1 January 2004.

The Rules are issued by the Hockey Rules Board under the authority of the International Hockey Federation. Copyright is held by the International Hockey Federation.

Availability of the Rules

Information about the availability of the Rules on the FIH website and about the purchase of Rules books is included at the end of this publication.

CONTENTS

Introduction 4

Terminology 10

PLAYING THE GAME

1 Field of play 13

2 Composition of teams 15

3 Captains 18

4 Players' clothing and equipment 18

5 Match and result 20

6 Start and re-start the match 21

7 Ball outside the field 22

8 Method of scoring 23

9 Conduct of play: players 23

10 Conduct of play: goalkeepers 27

11 Conduct of play: umpires 28

12 Penalties..... 29

13 Procedures for taking penalties 31

14 Personal penalties 38

UMPIRING

1 Objectives 39

2 Applying the Rules..... 40

3 Umpiring skills..... 42

4 Signals..... 45

Additional Information Available.....final text

INTRODUCTION

The Content of The Rules Book

This edition of the Rules of Hockey is presented in a new style. Our aim is to make the Rules easier to understand for everyone involved in the game so that we can play to common and enjoyable standards.

The language used has been simplified, descriptions are clearer and the layout is neater. We have made the order in which the Rules are presented more logical and incorporated any necessary explanatory notes in italics beneath the relevant Rule. There are two main sections to the Rules: "Playing the Game" and "Umpiring". At the end of the Rules, there is a description of additional information available from the International Hockey Federation (FIH).

With effect from this set of Rules, the implementation date is standardised as 1 January each year. A standard implementation date will in future allow participants to plan ahead for any Rules changes which are introduced.

For international competition, the date of implementation of this set of Rules is 1 January 2004 although National Associations have discretion to decide the date of implementation at national level.

While this revised set of Rules was being drawn up, the opportunity was taken to introduce some minor Rules changes.

2004 Rules Changes

Because the Rules text has been completely re-written, the 2004 Rules of Hockey should be studied in their entirety. However, we also draw attention to the more notable Rules changes below.

- To enable the Rules to focus on what most hockey participants need to know about playing the game, detailed information about the field and playing equipment including the stick, ball and goalkeepers' equipment is no longer included in this main Rules publication but is available separately from the FIH Office or on the FIH website.
- The specification of how a penalty corner is completed has been simplified and standardised. Completion for substitution purposes (Rule 2.4) is now consistent with completion at the end of half-time and full-time (13.4).
- Control of players who leave the field temporarily other than for substitution is clarified (2.5).
- How the result of a match is decided is specified (5.2).
- Procedures for starting and re-starting play have been rationalised. The Rules specify that the procedures for taking a free hit now apply to the centre pass (6.4) and to putting the ball back into play (7.3 and 7.4.a and b).
- The fundamental characteristics of the bully have been retained but it has been simplified by requiring sticks to touch only once (6.5.c).
- The former Rule which specified that a ball must not be raised intentionally so that it lands directly in the circle has been deleted. Wherever it lands, any ball must not be dangerous.
- The obstruction Rule has been simplified by referring in the Rule itself only to the fundamental principle that "players must not obstruct an opponent who is attempting to play the ball" (9.10). The explanatory notes in italics provide additional information.

- There is a specific requirement to avoid bodily contact when tackling (9.11).
- Players must not change their stick between the award and completion of a penalty corner or penalty stroke (9.14).
- The “advantage Rule” is specified more simply and clearly (12.1).
- The player taking a penalty stroke must start by standing behind and within playing distance of the ball (13.5.c) and must not approach either the ball or the goalkeeper after taking the stroke (13.5.j), but the former complex limitation of taking only one step forward has been deleted.
- The Rules now specify that the whistle must be blown to start a penalty stroke when both players are in position (rather than requiring the umpire to confirm that both are ready which can cause confusion in the absence of a common spoken language) (13.5.f).
- How offences at a penalty stroke are dealt with has been rationalised. In particular it is now clear that the penalty stroke is taken again if a goalkeeper prevents a goal being scored but leaves the goal-line or moves either foot before the ball has been played (13.7.b).
- To improve control of player conduct and therefore to protect the image of hockey, the intended duration of a temporary suspension may be extended for misconduct by a player while suspended (14.4).
- New umpiring signals have been introduced to indicate dangerous play and stick obstruction (Umpiring section: 4.5.a and g).

MANDATORY EXPERIMENTAL RULES

The two Mandatory Experimental Rules introduced in 2003 continue to apply in 2004. They are:

- permitting a defender to use the stick to stop or deflect a shot at goal at any height (9.5).
- not requiring the ball to be stopped before a shot at goal at a penalty corner (13.3.j).

These modifications of the Rules are classified as Mandatory Experiments so that they are scrutinised closely. Their impact on the game will be monitored by the Hockey Rules Board. In due course a decision will be made about whether or not to incorporate them as formal Rules.

RULES TRIALS

The Hockey Rules Board continues to consider ways in which the game might develop. Its objectives include:

- ensuring the game is easily understood by players, umpires, spectators and the media
- recognising the importance of safety, skill and fair play
- retaining the distinct characteristics of the game.

The main trial currently being pursued requires that at least three players from each team remain outside the 23 metres area their team is defending. As a result the 23 metres area seems to be less crowded and more attractive attacking play occurs. Other beneficial effects include a reduction in the frequency of hard hits into the circle and therefore an improvement in safety. However, there is also a concern that play is artificially interrupted at the 23 metres line and that counter-attacks might be broken down intentionally. The

trial is therefore continuing so that the balance of these effects can be assessed.

The Hockey Rules Board hopes that National Associations will continue to conduct trials of this Rule at all levels of hockey. In addition, the FIH will be applying this Rule in a small number of international tournaments over the next year or so. This will provide an additional opportunity for rigorous assessment of the effects of the trial Rule.

Trials and other Rules development activity are co-ordinated by the Rules Development Secretary, Peter von Reth. Peter is keen to receive feedback and comment on development ideas and can be contacted at Opaal 29, 5629 HP Eindhoven, Netherlands (email vonreth@iae.nl).

THE FUTURE

The new approach to the presentation of the Rules in this 2004 edition is an example of the International Hockey Federation looking to the future of hockey. FIH aims include making the game as attractive as possible to participate in and to watch while maintaining its distinctive characteristics. The Rules make a significant contribution to these aims.

The Hockey Rules Board therefore continues to review the Rules of the Hockey and will play its part in ensuring that hockey remains a game of which we are proud and which we enjoy.

Roger Webb
Secretary
Hockey Rules Board

84 Main Street
Hardwick
Cambridge CB3 7QU
England

MEMBERSHIP OF THE HOCKEY RULES BOARD AS AT 1 JANUARY 2004

Chairman:	Wolfgang Rommel
Secretary:	Roger Webb
Rules Development Secretary:	Peter von Reth
Members:	
Richard Aggiss	Seif El Dine Ahmed
Jorge Alcover	Gill Clarke
Eric Donegani	M P Ganesh
Eduardo Guelfand	Masako Kamisuki
Michael Krause	Evlyn Raistrick
Alain Renaud	Roger Self
Yung Hee Shin	Islah-Ud-Din Siddiqui
Gulansingham Vijayanathan	Heinz Wöltje

TERMINOLOGY

Player

One of the participants in a team.

Team

A team consists of a maximum of sixteen persons composed of eleven players on the field and up to five substitutes.

Field Player

One of the participants on the field other than the goalkeeper.

Attack (Attacker)

The team (player) which is trying to score a goal.

Defence (Defender)

The team (player) which is trying to prevent a goal being scored.

Back-line

The shorter (55 metres) perimeter line.

Goal-line

The back-line between the goal-posts.

Side-line

The longer (91.40 metres) perimeter line.

Circle

The area enclosed by and including the two quarter circles and the lines joining them at each end of the field opposite the centre of the back-lines.

23 metres area

The area enclosed by and including the line across the field 22.90 metres from each back-line, the relevant part of the side-lines, and the back-line.

Playing the ball

Stopping, deflecting or moving the ball with the stick; in the case of the goalkeeper also stopping, deflecting or moving the ball with the stick, kickers or leg-guards.

Hit

Striking the ball using a swinging movement of the stick towards the ball.

Push

Moving the ball along the ground using a pushing movement of the stick after the stick has been placed close to the ball. When a push is made, both the ball and the head of the stick are in contact with the ground.

Flick

Pushing the ball so that it is raised off the ground.

Scoop

Raising the ball off the ground by placing the head of the stick under the ball and using a lifting movement.

Shot at goal

The action of an attacker attempting to score by playing the ball towards the goal from within the circle.

Playing distance

The distance within which a player is capable of reaching the ball to play it.

Tackle

An action to stop an opponent retaining possession of the ball.

Offence

An action contrary to the Rules penalised by an umpire.

PLAYING THE GAME

1 Field of Play

The information and diagrams below provide a simplified description of the field of play. A detailed specification of the field and equipment is available from the FIH Office.

- 1.1 The field of play is rectangular, 91.40 metres long and 55.00 metres wide.
- 1.2 Side-lines mark the longer perimeters of the pitch; back-lines mark the shorter perimeters of the pitch.
- 1.3 The goal-lines are the parts of the back-lines between the goal-posts.
- 1.4 A centre-line is marked across the middle of the field.
- 1.5 Lines known as 23 metres lines are marked across the field 22.90 metres from each back-line.
- 1.6 Areas referred to as the circles are marked inside the field around the goals and opposite the centres of the back-lines.
- 1.7 All lines are 75 mm wide and are part of the field of play.
- 1.8 Flag-posts between 1.20 and 1.50 metres in height are placed at each corner of the field.
- 1.9 Goals are positioned outside the field of play at the centre of and touching each back-line.

Figure 1: Field of Play

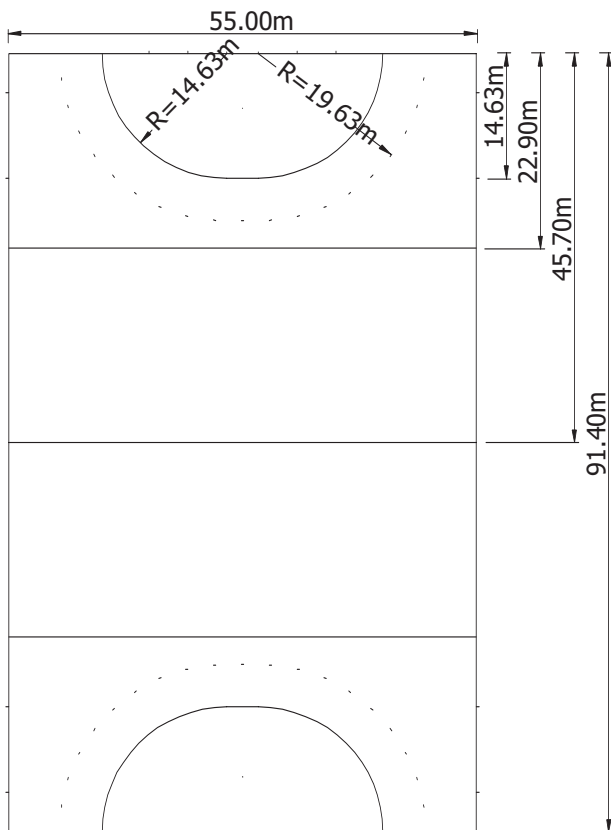
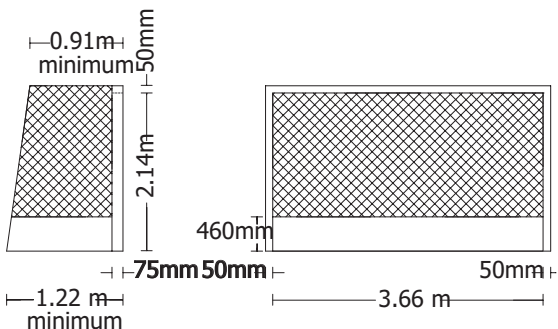

Figure 2: Goal



2 Composition of Teams

- 2.1 A match is played between two teams with not more than eleven players of each team on the field at the same time.
- 2.2 Each team must have a goalkeeper on the field at all times during play:
- an incapacitated or suspended goalkeeper must be replaced by another goalkeeper or field player acting as a goalkeeper
 - during the suspension of a goalkeeper, the team concerned has one less field player.

*At the completion of a temporary suspension, the captain is permitted:
to re-instate the temporarily suspended goalkeeper*

or

to continue to play with the replacement goalkeeper, in which case another field player can enter the field.

2.3

Each team is permitted to substitute from a maximum of sixteen players:

- a substitution is permitted at any time except within the period from the award of a penalty corner until after it has been completed; during this period substitution is only permitted for injury to or suspension of the defending goalkeeper
- b there is no limit to the number of players who are permitted to be substituted at the same time or to the number of times any player is permitted to substitute or be substituted
- c substitution of a player is permitted only after that player has left the field
- d substitutions are not permitted for suspended players during their suspension

For the duration of a temporary suspension, the offending team plays with one less player. For each permanent suspension, the offending team plays for the remainder of the match with one less player.

- e after completing a suspension, a player is permitted to be substituted without first returning to the field
- f field players must leave or enter the field for substitution purposes within 3 metres of the centre-line on a side of the field agreed with the umpires
- g goalkeepers are permitted to leave or enter the field for substitution near the goal they are defending
- h time is stopped for substitutions of goalkeepers but not for substitutions of field players.

- 2.4 For substitution purposes, a penalty corner is completed when:
- a a goal is scored
 - b an attacker commits an offence
 - c the ball travels more than 5 metres outside the circle
 - d the ball travels outside the circle for the second time
 - e the ball is played over the back-line and another penalty corner is not awarded
 - f a defender commits an offence and another penalty corner is not awarded
 - g a penalty stroke is awarded
 - h a bully is awarded.

If another penalty corner is awarded, substitution must not take place until that penalty corner has been completed.

- 2.5 Field players who leave the field for injury treatment, refreshment, to change equipment or for some reason other than substitution are permitted to re-enter only between the 23 metres areas.
- 2.6 No persons other than field players, goalkeepers and umpires are permitted on the field during play without the permission of an umpire.
- 2.7 Players on or off the field are under the jurisdiction of the umpires throughout the match including the half-time interval.

- 2.8 A player who is injured or bleeding must leave the field unless medical reasons prevent this and must not return until wounds have been covered; players must not wear blood stained clothing.

3 Captains

- 3.1 One player of each team must be appointed as captain.
- 3.2 A replacement captain must be appointed when a captain is suspended.
- 3.3 Captains must wear a distinctive arm-band or similar distinguishing article on an upper arm or shoulder.
- 3.4 Captains are responsible for the behaviour of all players on their team and for ensuring that substitutions of players on their team are carried out correctly.

A personal penalty is awarded if a captain does not exercise these responsibilities.

4 Players' Clothing and Equipment

Tournament Regulations available from the FIH Office provide additional information and requirements about players' clothing, personal equipment and advertising. Refer also to regulations established by Continental Federations and National Associations.

- 4.1 Field players of the same team must wear uniform clothing.

- 4.2 Players must not wear anything which is dangerous to other players.

Field players are permitted to wear gloves for protection which do not increase the natural size of the hands significantly. It is recommended that field players wear shin, ankle and mouth protection.

- 4.3 Goalkeepers must wear over any upper body protection a shirt or garment which is different in colour from that of both teams.

- 4.4 Protective headgear is compulsory for goalkeepers except when taking a penalty stroke.

A helmet incorporating fixed full-face protection and cover for the entire head and throat is recommended.

It is also recommended that goalkeepers wear other protective equipment. The following are permitted for use only by goalkeepers: body, upper arm, elbow, forearm, hand and thigh protectors, leg guards and kickers.

A detailed specification of equipment goalkeepers are permitted to use is available from the FIH Office.

- 4.5 Clothing or protective equipment which significantly increases the natural size of a goalkeeper's body or area of protection is not permitted.

- 4.6 The stick has a traditional shape with a handle and a curved head which is flat on its left side:

- a the stick must be smooth and must not have any rough or sharp parts
 - b inclusive of any additional coverings used, the stick must be able to pass through a ring with an interior diameter of 51 mm
 - c the stick must conform with the specification agreed by the Hockey Rules Board.
- 4.7 The ball is hard, white (or as agreed) and spherical.

A detailed specification of the stick and the ball is available from the FIH Office.

Match and Result

- 5.1 A match consists of two periods of 35 minutes and a half-time interval of 5 minutes.

Other periods and interval may be agreed by both teams except as specified in regulations for particular competitions.

- 5.2 The team scoring the most goals is the winner; if no goals are scored, or if the teams score an equal number of goals, the match is drawn.

Information about extra time and a penalty stroke competition as ways of reaching a result in a drawn match is included in Tournament Regulations available from the FIH Office.

6 Start and Re-start the Match

- 6.1 A coin is tossed and the team which wins the toss has the choice of which goal to attack in the first half of the match or to start the match with a centre pass.
- 6.2 Direction of play is reversed in the second half of the match.
- 6.3 A centre pass is taken:
- a to start the match by a player from the team winning the toss if they chose this option; otherwise by a player from the opposing team
 - b after half-time by a player of the team which did not take the centre pass to start the match
 - c after a goal by a player of the team against which the goal was scored or awarded.
- 6.4 Taking a centre pass:
- a taken at the centre of the field
 - b it is permitted to play the ball in any direction
 - c all players other than the player taking the centre pass must be in the half of the field which includes the goal they are defending
 - d the procedures for taking a free hit apply.
- 6.5 A bully takes place to re-start a match when time or play has been stopped for an injury or for any other reason and no penalty has been awarded:

- a a bully is taken close to the location of the ball when play was stopped but not within 15 metres of the back-line
 - b the ball is placed between one player from each team who face each other with the goal they are defending to their right
 - c the two players start with their sticks on the ground to the right of the ball and then tap the flat faces of their sticks together once just over the ball after which either player is permitted to play the ball
 - d all other players must be at least 5 metres from the ball.
- 6.6 A free hit is taken by a defender 15 metres in front of the centre of the goal-line to re-start a match when a penalty stroke has been completed and no goal has been scored or awarded.

7 Ball Outside the Field

- 7.1 The ball is out of play when it passes completely over the side-line or back-line.
- 7.2 A player of the team which was not last to touch the ball before it went out of play re-starts play.
- 7.3 When the ball travels over the side-line, play is re-started where the ball crossed the line and the procedures for taking a free hit apply.
- 7.4 When the ball is played over the back-line and no goal is scored:
- a if played by an attacker, play is re-started with the ball up to 15 metres from and in line with where it crossed the back-line and the

procedures for taking a free hit apply

- b if played unintentionally by a defender or deflected by a goalkeeper, play is re-started with the ball on the mark 5 metres from the corner of the field on the side-line nearest to where the ball crossed the back-line and the procedures for taking a free hit apply
- c if played intentionally by a defender, unless deflected by a goalkeeper, play is re-started with a penalty corner.

8 Method of Scoring

- 8.1 A goal is scored when the ball is played within the circle by an attacker and does not travel outside the circle before passing completely over the goal-line and under the cross-bar.

The ball may be played by a defender or touch their body before or after being played in the circle by an attacker.

9 Conduct of Play: Players

- 9.1 Players must not use the stick in a dangerous way.

Players must not lift their stick over the heads of other players.

- 9.2 Players must not touch, handle or interfere with other players or their sticks or clothing.

- 9.3 Players must not intimidate or impede another player.

- 9.4 Players must not play the ball with the back of the stick.

Mandatory Experimental Rule:

- 9.5 Players must not play the ball with any part of the stick when the ball is above shoulder height except that defenders are permitted to use the stick to stop or deflect a shot at goal at any height.**

If a defender attempts to stop or deflect a ball travelling towards the goal which will actually miss the goal, any use of the stick above the shoulder must be penalised by a penalty corner and not a penalty stroke. If dangerous play results after a legitimate stop or deflection, a penalty corner must be awarded. If instead of stopping or deflecting a shot the ball is hit while above shoulder height and a goal is prevented, a penalty stroke must be awarded.

- 9.6 Players must not play the ball dangerously or in a way which leads to dangerous play.

A ball is considered dangerous when it causes legitimate evasive action by players.

The penalty is awarded where the action causing the danger took place.

- 9.7 Players must not intentionally raise the ball from a hit except for a shot at goal.

A raised hit must be judged explicitly on whether or not it is raised intentionally.

It is not an offence to raise the ball unintentionally from a hit, including a free hit, anywhere on the field unless it is dangerous.

If the ball is raised over an opponent's stick or body on the ground, even within the circle, it is permitted unless judged to be dangerous.

Players are permitted to raise the ball with a flick or scoop provided it is not dangerous. A flick or scoop towards an opponent within 5 metres is considered dangerous.

- 9.8 Players must not approach within 5 metres of an opponent receiving a falling raised ball until it has been received, controlled and is on the ground.

The initial receiver has a right to the ball. If it is not clear which player is the initial receiver, the player of the team which raised the ball must allow the opponent to receive it.

- 9.9 Field players must not stop, kick, propel, pick up, throw or carry the ball with any part of their body.

It is not an offence if the ball hits the foot, hand or body of a field player, unless that player or their team benefits from this.

No offence is committed if the ball hits the hand holding the stick but would otherwise have hit the stick.

- 9.10 Players must not obstruct an opponent who is attempting to play the ball.

Players obstruct if they:

- *back into an opponent*
- *physically interfere with the stick or body of an opponent*
- *shield the ball from a legitimate tackle with their stick or any part of their body.*

A stationary player receiving the ball is permitted to face in any direction.

A player with the ball is permitted to move off with it in any direction except bodily into an opponent.

A player who runs in front of or blocks an opponent to stop them legitimately playing or attempting to play the ball is obstructing (this is third party or shadow obstruction). This also applies if an attacker runs across or blocks defenders (including the goalkeeper) when a penalty corner is being taken.

- 9.11 Players must not tackle unless in a position to play the ball without body contact.
- 9.12 Players must not intentionally enter the goal their opponents are defending.
- 9.13 Players must not force an opponent into offending unintentionally.

Playing the ball clearly and intentionally into any part of an opponent's body may be penalised as an attempt to manufacture an offence. Forcing an opponent to obstruct (often emphasised by running into an opponent or by waving the stick) must also be penalised.

- 9.14 Players must not change their stick between the award and completion of a penalty corner or penalty stroke unless it no longer meets the stick specification.
- 9.15 Players must not throw any object or piece of equipment onto the field, at the ball, or at another player, umpire or person.
- 9.16 Players must not delay play to gain benefit by time-wasting.

10 Conduct of Play: Goalkeepers

- 10.1 Goalkeepers must not take part in the match outside the half of the field they are defending, except when taking a penalty stroke.
- 10.2 When the ball is inside the circle they are defending and they have their stick in their hand, goalkeepers are permitted to:
- a use their stick, protective equipment or any part of their body to stop the ball
 - b use their stick, protective equipment or any part of their body to deflect the ball in any direction including over the back-line
 - c use their stick, kickers or leg guards to play the ball.

- 10.3 Goalkeepers must not lie on the ball.
- 10.4 When the ball is outside the circle they are defending, goalkeepers are only permitted to play the ball with their stick.

11 Conduct of Play: Umpires

- 11.1 Two umpires control the match, apply the Rules and are the judges of fair play.
- 11.2 Each umpire has primary responsibility for decisions in one half of the field for the duration of the match.
- 11.3 Each umpire is responsible for decisions on free hits in the circle, penalty corners, penalty strokes and goals in one half of the field.
- 11.4 Umpires are responsible for keeping a written record of goals scored or awarded and of warning or suspension cards used.
- 11.5 Umpires are responsible for ensuring that the full time is played and for indicating the end of time for each half and for the completion of a penalty corner if a half is prolonged.
- 11.6 Umpires blow the whistle to:
- a start and end each half of the match
 - b start a bully
 - c enforce a penalty
 - d start and end a penalty stroke
 - e indicate a goal
 - f re-start the match after a goal has been scored or awarded

- g re-start the match after a penalty stroke when a goal was not scored or awarded
- h stop the match for the substitution of a goal-keeper
- i stop the match for any other reason and to re-start it
- j indicate, when necessary, that the ball has passed wholly outside the field.

11.7 Umpires must not coach during a match.

11.8 If the ball strikes an umpire, unauthorised person or any loose object on the field, play continues.

12 Penalties

12.1 Advantage: a penalty is awarded only when a player or team has been disadvantaged by an opponent breaking the Rules.

If awarding a penalty is not an advantage to the team which did not break the Rules, play must continue.

12.2 A free hit is awarded to the opposing team:

- a for an offence by any player between the 23 metres areas
- b for an offence by an attacker within the 23 metres area their opponents are defending
- c for an unintentional offence by a defender outside the circle but within the 23 metres area they are defending.

12.3 A penalty corner is awarded:

- a for an offence by a defender in the circle which does not prevent the probable scoring of a goal
- b for an intentional offence in the circle by a defender against an opponent who does not have possession of the ball or an opportunity to play the ball
- c for an intentional offence by a defender outside the circle but within the 23 metres area they are defending
- d for intentionally playing the ball over the back-line by a defender

Goalkeepers are permitted to deflect the ball with their stick, protective equipment or any part of their body in any direction including over the back-line.

- e when the ball becomes lodged in a player's clothing or equipment while in the circle they are defending.

12.4 A penalty stroke is awarded:

- a for an offence by a defender in the circle which prevents the probable scoring of a goal
- b for an intentional offence in the circle by a defender against an opponent who has possession of the ball or an opportunity to play the ball
- c for defenders persistently crossing over the back-line before permitted during the taking of penalty corners.

12.5 If there is another offence or misconduct before the awarded penalty has been taken:

- a a free hit may be progressed up to 10 metres
 - A free hit to the attack cannot be progressed to inside the circle.*
- b a more severe penalty may be awarded
- c a personal penalty may be awarded
- d the penalty may be reversed if the subsequent offence was committed by the team first awarded the penalty.

13 Procedures for Taking Penalties

13.1 Location of a free hit:

- a a free hit is taken close to where the offence occurred

'Close to' means within playing distance of where the offence occurred and with no significant advantage gained.

The location from which a free hit is taken must be more precise inside the 23 metres area especially when the offence occurs close to the circle.

A free hit to the attacking team a small distance outside the circle must not be dragged inside the circle; the ball must leave the stick before entering the circle.

- b a free hit awarded outside the circle to the defence within 15 metres of the back-line is taken up to 15 metres from the back-line in line with the location of the offence, parallel to the side-line.

- c a free hit awarded inside the circle to the defence is taken anywhere inside the circle or up to 15 metres from the back-line in line with the location of the offence, parallel to the side-line.

13.2

Procedures for taking a free hit, centre pass and putting the ball back into play after it has been outside the field:

- a the ball must be stationary
- b the ball is pushed or hit and must move at least one metre before another player of the team which took the free hit is allowed to play it

A 'dragging' action used to play the ball at a free hit must not result in playing the ball twice.

- c the ball must not be raised intentionally
- d after playing the ball, the player taking the free hit must not play the ball again or approach within playing distance of it until it has been played by another player
- e opponents must be at least 5 metres from the ball.

If a player is standing within 5 metres of the ball but not influencing play, the free hit need not be delayed.

- f when a free hit is awarded to the attack within 5 metres of the circle, all players other than the player taking the free hit must be at least 5 metres from the ball.

13.3

Taking a penalty corner :

- a the ball is placed on the back-line inside the circle at least 10 metres from the goal-post on whichever side of the goal the attacking team prefers
- b an attacker pushes or hits the ball without intentionally raising it
- c the attacker taking the push or hit from the back-line must have at least one foot outside the field
- d the other attackers must be on the field, outside the circle with sticks, hands and feet not touching the ground inside the circle
- e no defender or attacker other than the attacker taking the push or hit from the back-line is permitted to be within 5 metres of the ball when the push or hit is taken
- f not more than five defenders, including the goalkeeper, must be positioned behind the back-line with their sticks, hands and feet not touching the ground inside the field
- g the other defenders must be beyond the centre-line
- h until the ball has been played, no attacker other than the one taking the push or hit from the back-line is permitted to enter the circle and no defender is permitted to cross the centre-line or back-line
- i after playing the ball, the attacker taking the push or hit from the back-line must not play the ball again or approach within playing distance of it until it has been played by another player

Mandatory Experimental Rule:

- j **no shot at goal is permitted until the ball has travelled outside the circle**
- k if the first shot at goal is a hit (as opposed to a push, flick or scoop), the ball must cross the goal-line, or be on a path which would have resulted in it crossing the goal-line, at a height of not more than 460 mm (the height of the backboard) before any deflection, for a goal to be scored

The requirements of this Rule apply even if the ball touches the stick or body of a defender before the first shot at goal.

If the first shot at goal is a hit and the ball is, or will be, too high crossing the goal-line it must be penalised even if the ball is subsequently deflected off the stick or body of another player.

The ball may be higher than 460 mm during its flight before it crosses the goal-line provided there is no danger and provided it would drop of its own accord below 460 mm before crossing the line.

'Slap' hitting the ball, which involves a long pushing or sweeping movement with the stick before making contact with the ball, is regarded as a hit.

- l for second and subsequent hits at the goal and for flicks, deflections and scoops, it is permitted to raise the ball to any height but this must not be dangerous

If a defender is within five metres of a shot during the taking of a penalty corner and is struck by the ball below the knee, another penalty corner must be awarded.

If a defender is within five metres of a shot and struck above the knee in a normal stance, the shot is judged to be dangerous and a free hit must be awarded to the defending team.

- m the attacker taking the push or hit from the back-line is not permitted to score directly

The ball must be played inside the circle by another attacker before a goal can be scored.

- n the penalty corner Rules no longer apply if the ball travels more than 5 metres from the circle.

13.4

The match is prolonged at half-time and full-time to allow completion of a penalty corner or any subsequent penalty corner or penalty stroke; for this purpose, the penalty corner is completed when:

- a a goal is scored
- b an attacker commits an offence
- c the ball travels more than 5 metres outside the circle
- d the ball travels outside the circle for the second time
- e the ball is played over the back-line and a penalty corner is not awarded
- f a defender commits an offence which does not result in another penalty corner

- g a penalty stroke is awarded.

If play is stopped during the taking of a penalty corner because of an injury or for any other reason and no penalty has been awarded, the penalty corner must be taken again.

13.5 Taking a penalty stroke:

- a time is stopped when a penalty stroke is awarded
- b all players on the field other than the player taking the stroke and the defending goalkeeper must stand outside the 23 metres area and must not influence the taking of the stroke
- c the player taking the stroke must stand behind and within playing distance of the ball before beginning the stroke
- d the defending goalkeeper must stand with both feet on the goal-line and must not leave the goal-line or move either foot until the ball has been played
- e the defending goalkeeper must wear protective headgear
- f the whistle is blown when the player taking the stroke and the defending goalkeeper are in position
- g the player taking the stroke must not take it until the whistle has been blown

The player taking the stroke or the goalkeeper defending it must not delay the taking of the stroke.

- h the player taking the stroke must not feint at playing the ball
- i the player taking the stroke must push, flick or scoop the ball and is permitted to raise it to any height

Using a 'dragging' action to play the ball at a penalty stroke is not permitted.

- j the player taking the stroke must play the ball only once and must not subsequently approach either the ball or the goalkeeper.

13.6 The penalty stroke is completed when:

- a a goal is scored or awarded
- b the ball comes to rest inside the circle, lodges in the goalkeeper's equipment, is caught by the goalkeeper, or goes outside the circle.

13.7 For an offence during the taking of a penalty stroke:

- a by the player taking the stroke: a free hit is awarded to the defence
- b when the goalkeeper prevents a goal being scored but leaves the goal-line or moves either foot before the ball has been played: the penalty stroke is taken again

For the first offence of this type, the goalkeeper must be warned (green card) and for any subsequent offence the goalkeeper must be suspended (yellow card).

- c for any other offence by the goalkeeper which prevents a goal being scored: a goal is awarded

- d for an offence by the goalkeeper which does not prevent a goal being scored: the penalty stroke is taken again
- e for an offence by another player of either team: the penalty stroke is taken again.

14 Personal Penalties

- 14.1 For any offence, the offending player may be:
- a cautioned (indicated by spoken words)
 - b warned (indicated by a green card)
 - c temporarily suspended for a minimum of 5 minutes of playing time (indicated by a yellow card)
 - d permanently suspended from the current match (indicated by a red card).

A personal penalty may be awarded in addition to the appropriate penalty.

- 14.2 Temporarily suspended players must remain in a designated place until permitted by the umpire who suspended them to resume play.
- 14.3 Temporarily suspended players are permitted to rejoin their team at half-time after which they must return to a designated place to complete their suspension.
- 14.4 The intended duration of a temporary suspension may be extended for misconduct by a player while suspended.
- 14.5 Permanently suspended players must leave the field and its surrounding area.

UMPIRING

1 Objectives

- 1.1 Umpiring hockey is a challenging but rewarding way to participate in the game.
- 1.2 Umpires contribute to the game by:
- a helping to raise the standard of the game at all levels by ensuring that players observe the Rules
 - b ensuring that every game is played in the right spirit
 - c helping to increase the enjoyment of the game for players, spectators, and others.
- 1.3 These objectives can be achieved by umpires being:
- a consistent: umpires maintain the respect of players by being consistent
 - b fair: decisions must be made with a sense of justice and integrity
 - c prepared: no matter how long an umpire has been officiating, it is important to prepare thoroughly for every match
 - d focused: concentration must be maintained at all times; nothing must be allowed to distract an umpire
 - e approachable: a good understanding of the Rules must be combined with a good rapport with the players
 - f better: umpires must aim to become even better with each and every match

- g natural: an umpire must be themselves, and not imitate another person, at all times.

1.4 Umpires must:

- a have a thorough knowledge of the Rules of Hockey but remember that the spirit of the Rule and common sense must govern interpretation
- b support and encourage skilful play, deal promptly and firmly with offences and apply the appropriate penalties
- c establish control and maintain it throughout the match
- d use all the available tools for control
- e apply the advantage Rule as much as possible to assist a flowing and open match but without losing control.

2 Applying the Rules

2.1 Protecting skilful play and penalising offences:

- a the relative seriousness of an offence must be identified and serious offences such as dangerous or rough play dealt with early and firmly in a match
- b intentional offences must be penalised firmly
- c umpires must demonstrate that if players cooperate, skilful play will be protected and the match will be interrupted only when essential for its proper conduct.

2.2 Advantage:

- a it is not necessary for every offence to be penalised when no benefit is gained by the offender; unnecessary interruptions to the flow of the match cause undue delay and irritation

- b when the Rules have been broken, an umpire must apply advantage if this is the most severe penalty
- c having decided to play advantage, a second opportunity must not be given by reverting to the original penalty
- d it is important to anticipate the flow of the match, to look beyond the action of the moment and to be aware of potential developments in the match.

2.3

Control:

- a decisions must be made promptly, positively, clearly and consistently
- b strict action early in a match will usually discourage repetition of an offence
- c it is not acceptable for players to abuse opponents, umpires or other technical officials verbally or through body language and attitude. Umpires must deal firmly with abuse of this sort and in appropriate circumstances issue a caution, warning (green card), or a temporary (yellow card) or permanent (red card) suspension. Cautions, warnings and suspensions can be given in isolation or in combination with another penalty
- d cautions can be given to players in close proximity without stopping the match
- e it is possible for a player to receive two green or two yellow cards for different offences during the same match but when an offence for which a card has been awarded is repeated, the same card must not be used again and a more severe penalty must be awarded

- f when a second yellow card is awarded, the period of suspension must be significantly longer than the first suspension
- g there must be a clear difference between the duration of a yellow card suspension for a minor offence and the duration for a more serious and/or physical offence
- h when a player intentionally misbehaves in a serious manner towards another player, the red card must be shown immediately.

2.4 Penalties:

- a a wide range of penalties is available
- b two penalties can be used together to deal with bad or persistent offences.

3 Umpiring skills

3.1 The main umpiring skill areas are:

- a match preparation
- b co-operation
- c mobility and positioning
- d whistling
- e signalling.

3.2 Match preparation:

- a umpires must prepare thoroughly for each match by arriving at the field in good time
- b before the match commences, both umpires must check the field markings, the goals and the nets and check for any dangerous playing equipment or field equipment

- c the two umpires must wear similar colours to one another, but different from those of both teams
- d clothing appropriate to the conditions must be worn
- e footwear must suit field conditions and assist mobility
- f umpiring equipment includes a copy of the current Rules book, a loud and distinctive whistle, a stop watch, and materials to record match details.

3.3 Co-operation:

- a good team-work and co-operation between umpires is essential
- b prior to a match, umpires must discuss and agree how they are going to work together to assist each other. Eye contact between umpires must be practised and maintained
- c umpires must take responsibility and be prepared to assist when their colleague is unsighted or has difficulty seeing certain parts of the field. If necessary and if mobility is good, umpires must be prepared to cross the centre-line and go as far as appropriate into a colleague's half of the field to assist. This helps to reassure players that decisions are correct
- d a written record of goals scored and cards issued must be kept by both umpires and confirmed at the end of the match.

3.4 Mobility and positioning:

- a umpires must be mobile so they can move to appropriate positions throughout the match.

- b static umpires cannot view play clearly enough to make correct decisions at all times
- c fit, mobile and well positioned umpires are better able to concentrate on the flow of the match and on the decisions which need to be made
- d each umpire operates mainly in half of the field with the centre line to their left
- e in general, the most suitable position for umpires is ahead of and on the right of the attacking team
- f for play between the centre-line and 23 metres area, umpires must be positioned near their side-line
- g when play is in the 23 metres area or circle, umpires must move further into the field away from the side-lines and, when necessary, into the circle itself to see important offences and to judge whether shots at goal are legitimate
- h for penalty corners and after the ball has gone outside the field, umpires must take up a position which gives a clear view of all potential action
- i for penalty strokes, umpires must take up a position behind and to the right of the player taking the stroke
- j umpires must not allow their positioning to interfere with the flow of play
- k umpires must face the players all the time.

3.5

Whistling:

- a the whistle is the main way in which umpires communicate with players, each other and other persons involved in the match
- b the whistle must be blown decisively and loudly enough for all involved in the match to be able to hear it. This does not mean long loud whistling at all times
- c the tone and duration of the whistle must be varied to communicate the seriousness of offences to players.

3.6

Signalling:

- a signals must be clear and held up long enough to ensure that all players and the other umpire are aware of decisions
- b only the official signals must be used
- c it is preferable to be stationary when giving a signal
- d directional signals must not be made across the body
- e it is bad practice to look away from the players when a signal or decision is made; further offences might be missed, concentration can be lost, or this can indicate a lack of confidence.

4 Umpiring Signals

4.1

Timing:

- a start time: turn towards the other umpire with one arm straight up in the air
- b stop time: turn towards the other umpire and cross fully-extended arms at the wrists above the head

- c two minutes of play remaining: raise both hands straight up in the air with pointing index fingers
- d one minute of play remaining: raise one hand straight up in the air with pointing index finger.

Once a timing signal has been acknowledged no further time signal is needed.

4.2 Bully: move hands alternately up and down in front of the body with palms facing each other.

4.3 Ball out of play:

- a ball out of play over the side-line: indicate the direction with one arm raised horizontally
- b ball out of play over the back-line by an attacker: face the centre of the field and extend both arms horizontally sideways
- c ball out of play over the back-line unintentionally by a defender: point one arm at the corner flag nearest where the ball crossed the back-line.

4.4 Goal scored: point both arms horizontally towards the centre of the field.

4.5 Conduct of play:

Signals for conduct of play offences must be shown if there is doubt about the reason for the decision.

- a dangerous play: place one forearm diagonally across the chest
- b misconduct and/or bad temper: stop play and make a calming movement by moving both hands slowly up and down, palms downward, in front of the body

- c kick: slightly raise a leg and touch it near the foot or ankle with the hand
- d raised ball: hold palms facing each other horizontally in front of the body, with one palm approximately 150 mm above the other
- e obstruction: hold crossed forearms in front of the chest
- f third party or shadow obstruction: alternately open and close crossed forearms in front of the chest
- g stick obstruction: hold one arm out and downwards in front of the body half-way between vertical and horizontal; touch the forearm with the other hand
- h 5 metres distance: extend one arm straight up in the air showing an open hand with all fingers extended.

4.6

Penalties:

- a advantage: extend one arm high from the shoulder in the direction in which the benefiting team is playing
- b free hit: indicate the direction with one arm raised horizontally
- c free hit progressed up to 10 metres: raise one arm vertically with fist clenched
- d penalty corner: point both arms horizontally towards the goal
- e penalty stroke: point one arm at the penalty stroke mark and the other straight up in the air; this signal also indicates time stopped.

Additional Information Available

The International Hockey Federation can provide information on various topics to assist participation in the sport.

Indoor Hockey

A separate publication provides:

- the Rules of Indoor Hockey.

Field, Pitch and Equipment Specifications

Detailed information is available about:

- field dimensions and markings (outdoor/field hockey)
- pitch dimensions and markings (indoor hockey)
- goals (outdoor/field hockey)
- goals (indoor hockey)
- the stick
- the ball
- goalkeepers' equipment.

Synthetic Fields and Lighting (Outdoor)

Information is available about:

- performance requirements
- irrigation recommendations
- guidelines for care and maintenance
- approved synthetic pitch manufacturers
- artificial lighting.

Tournament Regulations and Management

Information includes:

- roles and responsibilities of tournament officials

- specification of team clothing, equipment and colours
- advertising on clothing and on / around the field
- interruptions of a match
- procedures for handling protests
- competition plan and ranking procedure (including a penalty stroke competition).

Umpiring

Information of interest to umpires includes:

- grading criteria for FIH umpires
- handbook for international umpires including information about umpiring skills, tournament and mental preparation and a fitness programme
- manual for umpires managers including information about duties, umpire coaching, fitness testing, performance feedback and assessor forms.

Hockey Development Resources

Various materials produced by hockey participants throughout the world are available in print, on video and on compact-disk. They include:

- beginner, development and elite coaching
- school and youth programmes
- mini-hockey
- course manuals.

The information above is available on the FIH website:

www.FIHockey.org

or from the FIH Office:

The International Hockey Federation
Avenue des Arts 1 Bte 5
B-1210 Brussels
Belgium

Telephone: ++32 (2) 219 4537

Fax: ++32 (2) 219 2761

E-mail: FIH@FIHockey.org

Copyright ©FIH 2003

The Copyright of these Rules is held by the International Hockey Federation. The contents may be reproduced or translated for distribution or resale by affiliated National Associations. Reprints must replicate the appearance of these Rules and incorporate the following text: "Reprinted with permission of the International Hockey Federation". National Associations seeking guidance on the reprinting of this Book must contact the FIH Office.

Purchase of Rules Books

- Payment must accompany each order.
- Each Rules Book costs €3 (or £2 for UK orders) excluding postage and handling.
- Remittances must be payable to the International Hockey Federation (or for UK orders to the Welsh Hockey Umpires Association or WHUA).
- All necessary contact details including name and full delivery address must accompany each order.
- Address orders to:

all orders (except UK addresses)

The International Hockey Federation
Avenue des Arts 1 Bte 5
B-1210 Brussels
Belgium

UK orders:

Colin Crayford
24 Rheidol Drive
Cwn Talwg
Barry
CF62 7HB
Wales

